

Ground fault monitor RCMA471LY

Ground Fault Monitor / Ground Fault Relay
for Grounded AC, DC, and AC/DC Systems

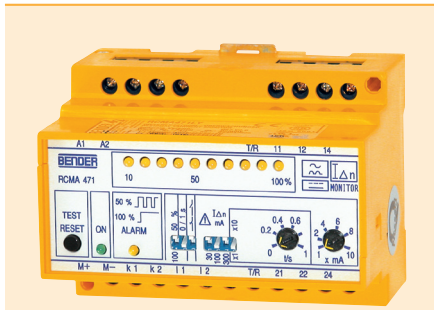

RCMA471LY

Device features

- External measuring current transformer
- Two separately adjustable response values
Alarm $I_{\Delta n1}$: 300 / 100 mA...3 A (0...60 Hz),
Prewarning $I_{\Delta n2}$: 50 % / 100 % of $I_{\Delta n1}$
- Adjustable response delay 0...10 s
(prewarning 0 / 1 s)
- Two separate voltage-free SPDT contacts
- Selectably operates normally energized
or normally de-energized
- Latching operation
- Combined TEST and RESET button
- Connection external TEST and RESET button
- LED bar graph indicator $I_{\Delta n}$ 0...100 %
- Connection for optional external measuring instrument $I_{\Delta n}$ 0...100 %
- CT connection monitoring
- Sealable transparent cover
- Separate supply voltage
- Type B acc. to IEC 60755

Approvals



Product description

The RCMA470LY monitors for ground faults in grounded and high-resistance grounded AC (both single- and three-phase), DC, and mixed AC/DC systems. The RCMA470LY is specially designed to provide advanced warning of developing ground faults without the problems associated with high sensitivity nuisance tripping.

A wide, steplessly adjustable range allows for flexibility in a variety of systems. In addition to the standard setpoint setting, a prewarning setting for 50% or 100% of the main alarm is available. These two alarms control two voltage-free SPDT contacts, allowing for information transmission (such as to a PLC) or power interruption (such as through a contactor or shunt trip breaker).

Since the values are measured with measuring current transformers, the device is nearly independent of the load current and the nominal voltage of the system. This device uses current transformers of 120 mm (4.7") and 210 mm (8.2"). For systems with smaller wire gauges, please refer to the RCMA470LY.

Application

- Ground fault detection in single- or three-phase AC systems
- Ground fault detection in pure DC or mixed AC/DC systems
- Variable frequency drives (VFDs)
- Uninterruptible power supplies (UPS)
- Construction site equipment
- Battery backup systems
- Laboratory equipment
- Photovoltaic systems
- Systems with larger wire gauges

Function

Measurements of the system's ground fault current are taken via external current transformers. All phases (including the neutral if one exists) are placed through the current transformer. The currently measured value (measured as a percentage of the setpoint) is indicated on the LED bar graph.

If the measured value exceeds one or both of the response values, the respective contacts switch over and the alarm LEDs activate after the time delay has expired. After the ground fault clears, the alarms will not clear until the device is reset manually or the supply voltage is lost.

The connections between the device and the external current transformer are continuously monitored. If the device detects a connection error, the CT connection monitoring alarm will be active and the contacts will change over without delay.

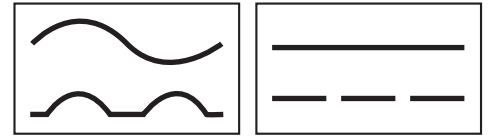

Wiring diagram – system connection, external connections

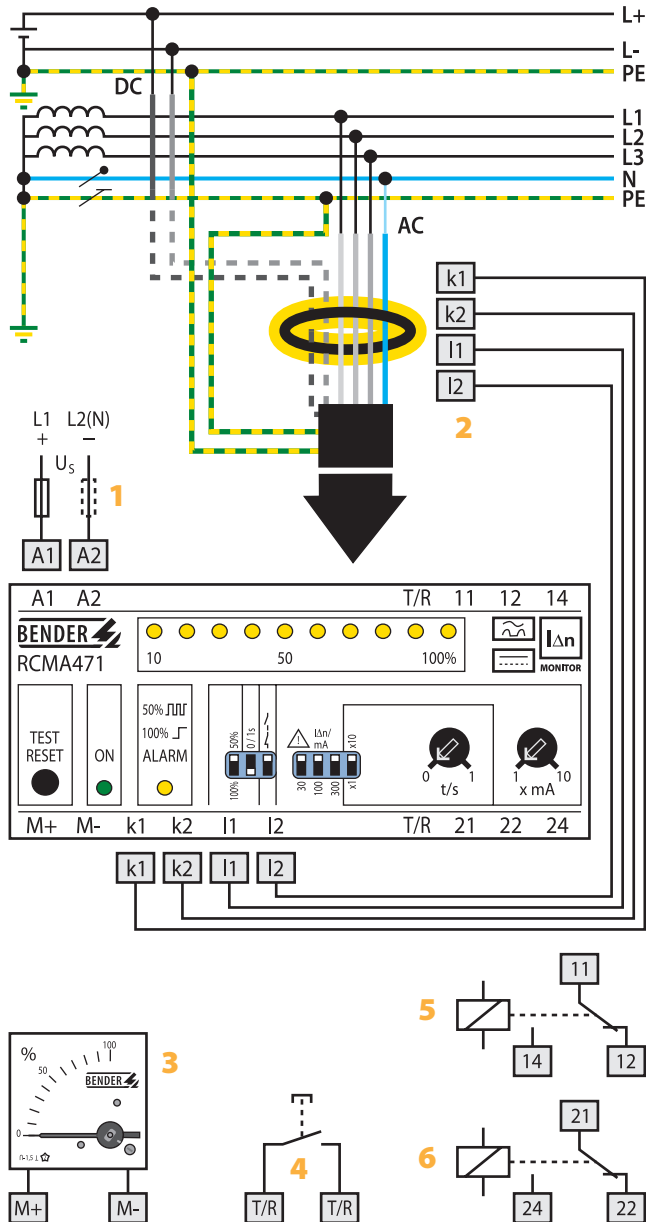

- 1 - Supply voltage U_s (see ordering information), a 6 A fuse recommended for internal protection.
- 2 - Connection to external current transformer. For AC, all phases (including a neutral if one exists) are placed through. For DC, both legs are placed through.
- 3 - Optional external measuring instrument
- 4 - External TEST and RESET button connection
- 5 - Alarm relay: Switches over when the main alarm or the CT connection alarm is active.
- 6 - Alarm relay: Switches over when the prewarning alarm or the CT alarm is active.

Do not route ground through with the power conductors!

Wiring diagram – front plate

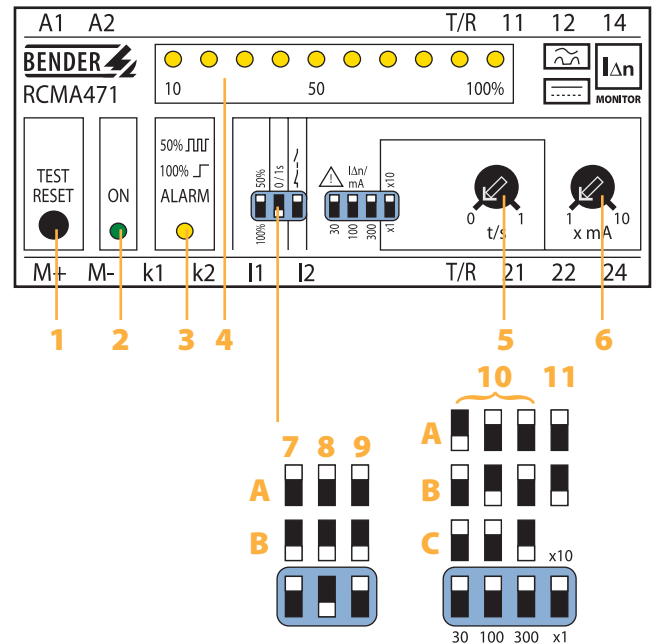

- 1 - Combined TEST and RESET button: short depress ($< 1\text{ s}$) = RESET, hold ($> 2\text{ s}$) = TEST.
- 2 - Power On LED: Illuminates when power is received to the device. Flashes when the CT connection alarm is active.
- 3 - Alarm LED: Illuminates when the main alarm is exceeded. Flashes when the prewarning alarm is exceeded.
- 4 - LED bar graph indicator: Displays the measured value as a percentage of the preset response value.
- 5 - Potentiometer for setting the response delay (0...1 s)
- 6 - Potentiometer for setting the response value (x 1...10 mA)

DIP switch settings (white = switch position)

- 7 - Prewarning response value (Contact 21-22-24)
 - A - at 50 % of $I_{\Delta n1}$
 - B - at 100 % of $I_{\Delta n1}$
- 8 - Prewarning response delay
 - A - Delay 1 s
 - B - Delay 0 s
- 9 - Alarm relay
 - A - Normally de-energized operation
 - B - Normally energized operation
- 10 - Response range
 - A - 30 mA
 - B - 100 mA
 - C - 300 mA

} x 1...10
- 11 - Response delay
 - A - Setting value t / s x10
 - B - Setting value t / s x1

Technical data: Ground fault monitor RCMA471LY

Insulation coordination acc. to IEC 60664-1

Rated insulation voltage	AC 250 V
Rated impulse voltage / pollution degree	4 kV / 3

Voltage ranges

Supply voltage U_S	see ordering information
Operating range of U_S	0.85...1.1 x U_S
Frequency range of U_S	DC / 50...60 Hz
Power consumption	≤ 3.5 VA

Measuring circuit / response values

External measuring current transformer	W...B series
Operating characteristic acc. to IEC 60755	Type B
Rated residual operating current $I_{\Delta n2}$ (prewarning)	50 / 100 % of $I_{\Delta n1}$
Response delay t_v	0 / 1 s
Rated residual operating current $I_{\Delta n1}$ (alarm)	W120B: 100 mA...3 A W210B: 300 mA...3 A
Response delay t_v , adjustable	0...10 s
Rated frequency	0...60 Hz
Relative percentage error	0...-25 %
Hysteresis	approx. 25 % of the response value
Response time t_{an} at $I_{\Delta n1} = 1 \times I_{\Delta n1} / 2$ ($t_v = 0$ s)	< 70 ms
Response time t_{an} at $I_{\Delta n1} = 5 \times I_{\Delta n1} / 2$ ($t_v = 0$ s)	< 40 ms

Displays

LED bar graph indicator	0...100 %
LEDs	Power On, prewarning, alarm

Inputs / outputs

TEST and RESET button	internal / external
Cable length external TEST and RESET button	≤ 10 m
Current source for external measuring instrument 0...100 %	DC 0...400 μ A
Load	≤ 12.5 k Ω

Cable lengths for measuring current transformers

Single wire ≥ AWG 20 (0.75 mm ²)	0...32.8 ft (0...10 m)
--	------------------------

Switching elements

Number of switching elements	2 SPDT contacts
Operating principle, adjustable	normally energized or de-energized
Electrical endurance, number of cycles	12000
Rated contact voltage	AC 250 V / DC 300 V
Limited making capacity	AC / DC 5 A
Breaking capacity	2 A, AC 230 V, PF = 0,4 0.2 A, DC 220 V, L / R = 0.04 s
Fault memory behavior	Latching operation

General data

EMC immunity	acc. to EN 61543
EMC emission	acc. to EN 61000-6-4
Shock resistance IEC 60068-2-27 (during operation)	15 g / 11 ms
Bumping IEC 60068-2-29 (during transport)	40 g / 6 ms
Vibration resistance IEC 60068-2-6 (during operation)	1 g / 10...150 Hz
Vibration resistance IEC 60068-2-6 (during transport)	2 g / 10...150 Hz
Ambient temperature, during operation	-25 °C...+70 °C
Ambient temperature, when stored	-40 °C...+75 °C
Climatic category IEC 60721-3-3	3K5
Operating mode	continuous operation
Mounting	any position
Connection	screw terminals
Connection properties	
rigid / flexible	0.2...4 / 0.2...2.5 mm ²
flexible with ferrules without / with plastic collar	0.25...2.5 mm ²
Conductor sizes (AWG)	24...12
Protection class, internal components (IEC 60529)	IP30, NEMA 1
Protection class, terminals (IEC 60529)	IP20, NEMA 1
Type of enclosure	X470
Enclosure material	polycarbonate
Screw mounting	2 x M4
DIN rail mounting acc. to	IEC 60715
Flammability class	UL94V-0
Standards	IEC 62020
Instruction leaflet	BP404002
Weight	≤ 350 g

Ordering information

Type	Response range $I_{\Delta n}$	Rated frequency	Time delay	Measuring current transformers	Indication	Fault memory	Supply voltage U_S	Art. No.
RCMA471LY	300 / 100 mA...3 A	0...60 Hz	0...10 s	W120B, W210B	internal / external	×	AC 230 V	B 9404 2005 ²⁾
RCMA471LY-13	300 / 100 mA...3 A	0...60 Hz	0...10 s	W120B, W210B	internal / external	×	AC 90...132 V*	B 9404 2006 ²⁾
RCMA471LY-21	300 / 100 mA...3 A	0...60 Hz	0...10 s	W120B, W210B	internal / external	×	DC 9.6...84V*	B 9404 2010 ¹⁾
RCMA471LY-23	300 / 100 mA...3 A	0...60 Hz	0...10 s	W120B, W210B	internal / external	×	DC 77...286V*	B 9404 2011 ¹⁾

Other supply voltages on request

* Absolute values of the operating range

¹⁾ For industrial application only





²⁾ For industrial and household applications

Accessories

External measuring current transformers		
Type	Inside diameter (mm)	Art. No.
W120B	∅ 120	B 9808 0031
W210B	∅ 210	B 9808 0037

External measuring instrument			
Type	Display range	Size (mm)	Art. No.
9604-4241	0...100 %	96 x 96	B 986 807

Measuring converter			
Type	Input	Output	Art. No.
RK170	0...400 µA	0...10 V / 0 / 4...20 mA	B 9804 1500

Conditions of operation according to IEC 60202, IEC 60755 amendment 2, Type B		
Type of current	Wave form	Tripping current
Alternating currents (50 Hz)		0.5...1 x I _{Δn}
Pulsed DC residual currents (positive and negative half waves) half-wave current		0.5...1.4 x I _{Δn}
Phase-controlled half-wave currents Current delay angle 90° el – 135° el		0.5...1.4 x I _{Δn}
Half-wave current superimposed by a smooth direct current of 6 mA		0.5...1.4 x I _{Δn}
Smooth DC residual current		0.5...2 x I _{Δn}

Dimension diagram X470

Dimensions in mm

